

# Axle Mount Flush Assemblies & Halves

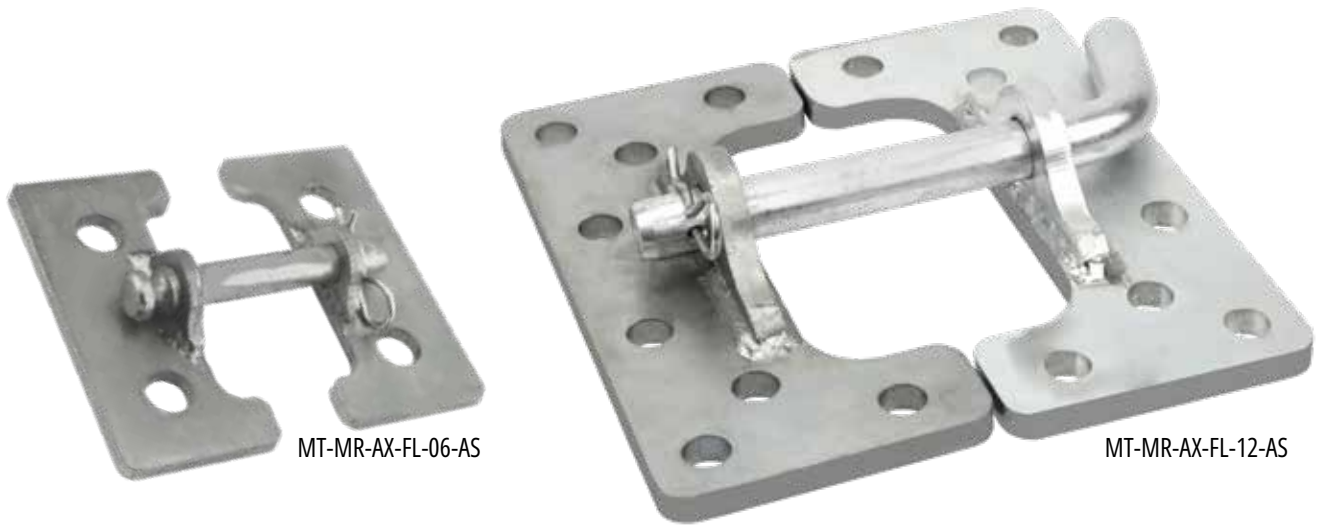

MT-MR-AX-FL-06-AS

MT-MR-AX-FL-12-AS



MT-MR-AX-FL-06-H

MT-MR-AX-FL-12-H

### PRO TIP

Can be used for wheels or pulleys.

<b>Standard Material</b>	A36 Low Carbon Steel
<b>Standard Finish</b>	10 - Zinc Clear
<b>Available Finish(es)</b>	10-12, 20-33
<b>Recommended Tools</b>	Tool Kit 1
<b>For More Info</b>	<a href="http://www.ModTruss.com">www.ModTruss.com</a>

Part # Description	Size	Weight	Hole Size	Recommended Hardware
<b>MT-MR-AX-FL-06-AS</b> 6" Flush Axle Mount Assembly	5.25" x 5.38" x 1.28" (133mm x 137mm x 33mm)	1.85lbs (0.45kg)	11/16" (17.46mm) 5/8" (15.87mm)	5/8"-11 Thread Grade 8 Bolt, 2" Long 5/8" SAE Zinc-Plated Washer 5/8"-11 Thread, Grade 8 Hex Nut
<b>MT-MR-AX-FL-06-H</b> 6" Flush Axle Mount Half (Pin and Sheave Not Included)	6.5" x 6" x 2.5" (165.10mm x 152.40mm x 63.50mm)	0.85lbs (0.39kg)	11/16" (17.46mm) 5/8" (15.87mm)	(M16 x 2 Thread, 50mm Long, Class 10.9 Bolt M16, Class 10.9 Washer M16 x 2 Thread, Class 10.9 Nut)
<b>MT-MR-AX-FL-12-AS*</b> 12" Flush Axle Mount Assembly	10.75" x 10.75" x 2.38" (273.05mm x 273.05mm x 60mm)	14.25lbs (6.46kg)	11/16" (17.46mm) 1" (25.40mm)	5/8"-11 Thread Grade 8 Bolt, 2.5" Long 5/8" SAE Zinc-Plated Washer 5/8"-11 Thread, Grade 8 Hex Nut
<b>MT-MR-AX-FL-12-H*</b> 12" Flush Axle Mount Half (Pin and Sheave Not Included)	10.5" x 5.13" x 2.38" (273mm x 130mm x 60mm)	5.85lbs (2.65kg)	11/16" (17.46mm) 1" (25.40mm)	(M16 x 2 Thread, 65mm Long, Class 10.9 Bolt M16, Class 10.9 Washer M16 x 2 Thread, Class 10.9 Nut)

\*Only 12" Flush Axle Mount Assembly is compatible with standard Truss



U.S. Patent No. 8,418,425 & other patents pending

TR

EX

PL

JH

PA

HG

MR

AC

HW

TK

MH

FH

GL

Series | MR Motion & Rigging

Product Number | MT-MR-AX-FL-XXX-AS

### MT-MR-AX-FL-12-AS

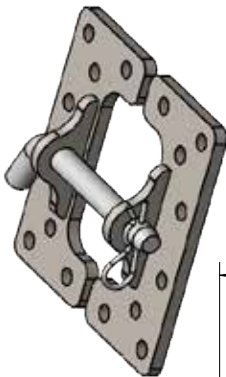
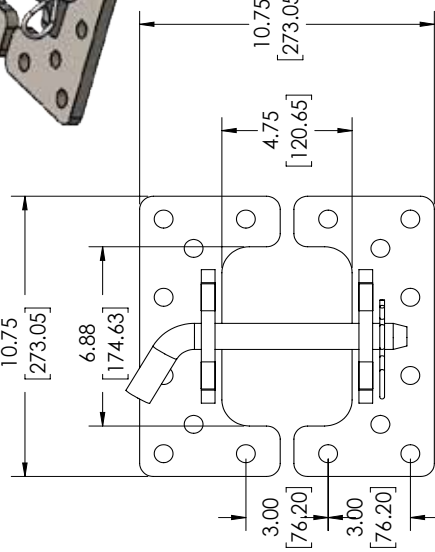
Dimensions: 10.75 [273.05], 6.88 [174.63], 4.75 [120.65], 10.75 [273.05], 3.00 [76.20], 3.00 [76.20]

### MT-MR-AX-FL-12-HF

Dimensions: 1.94 [49.21], 5.13 [130.18], 3.00 [76.20],  $\phi .69$  [17.46], 5.13 [130.18], 1.31 [33.34], 5.38 [136.53]

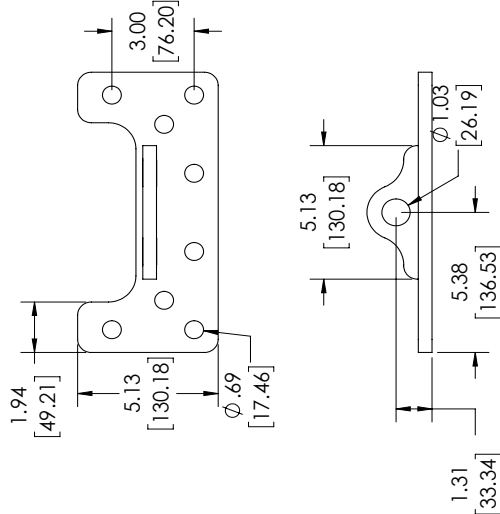
---

### MT-MR-AX-FL-06-AS



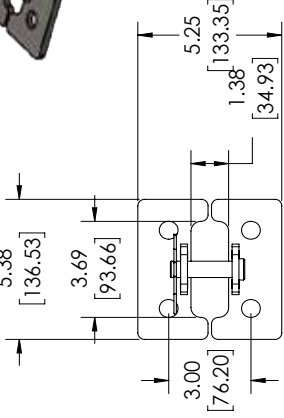

Dimensions: 5.38 [136.53], 3.69 [93.66], 5.25 [133.35], 1.38 [34.93], 3.00 [76.20]

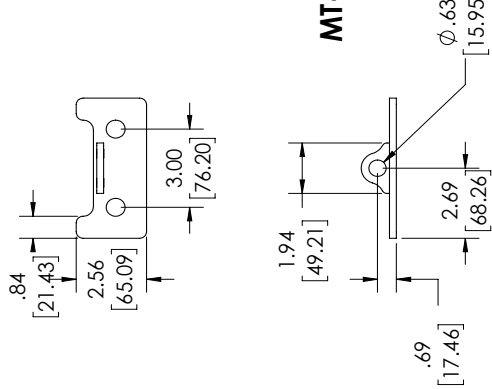
### MT-MR-AX-FL-06-HF

Dimensions: .84 [21.43], 2.56 [65.09], 3.00 [76.20], 1.94 [49.21],  $\phi .63$  [15.95], 2.69 [68.26], .69 [17.46]

	<b>ModTruss</b> <sup>INC</sup>	PRECISION LEVEL - MED - +.06 [-1.59] BRACKET (1 DIMENSIONS ARE IN MM)
DESCRIPTION:	8/5/2019	REVISION: V1
AXLE MOUNT		
PART NUMBER:		MT-MR-AX-FL-XX-XX